

**Britannia Arena
1661 Napier St.**

Health Check

VMHA members must **complete the TeamSnap Health Check PRIOR to arrival at the arena**. Health Check can be found in Event Details and is available 8 hours before the event.

A designated team official will check participants in and confirm the Health Check has been completed. Individuals will not be permitted to enter the building if the Health Check is incomplete/failed.

Entrance/Timing

Please arrive no more than 20 minutes prior to your ice time. Players and designated team officials will be allowed into the building 10 minutes before ice time. **No spectators are permitted.**

Masks are required. Players may remove their masks prior to stepping on the ice (helmets on). Off-ice, participants must wear masks at all times while in the building.

Arena entrance is on the upper concourse on the south side of the building and will be marked with a VMHA logo. Please wait in the designated area(s) (mask on, 2m from others) until the Rink Attendant opens the door for your group.

Practices

Please come to the rink mostly dressed. There will be marked areas for players to put on their skates, helmets & gloves.

Dressing areas are limited to 19 participants. Participants are to remain in the dressing area until a Rink Attendant lets them on to the ice. All personal belongings will remain in the dressing area until the players leave the arena.

Water stations are NOT available. Please fill your bottles before leaving for the rink.

No off-ice activities (dry-land/warm-up/stretching) are permitted inside the building.

At the end of practice, **participants will have FIVE (5) MINUTES to remove the minimum amount of equipment required to exit the arena** (skates, helmets & gloves). **Arena exit is via the lower doors on the south side of the building.**

Games

Dressing areas are not used. Water stations are NOT available.

No off-ice activities (dry-land/warm-up/stretching) are permitted inside the building.

Players* on BOTH teams arrive COMPLETELY dressed (with skate guards, helmets AND masks) and **access the ice immediately upon entering the facility.** It is recommended that players bring a small bag to hold their water bottle, skate guards, masks, etc. **Hockey bags are not permitted.**

*Goaltenders from both teams may arrive partially dressed and use a designated dressing area to put on their skates and pads. Coaches and officials (referees/linesmen) are also permitted to use this area.

At the end of the game, players will return to the bench and put on their masks before crossing the ice. They will put on their skate guards as they leave the ice and exit the facility immediately. Arena exit is via the lower doors on the south side of the building.

Additional Information

City of Vancouver arena capacity (games) is 45 participants; players, team officials, referees/linesmen, score & time-keepers only. NO SPECTATORS.

Arena map attached.

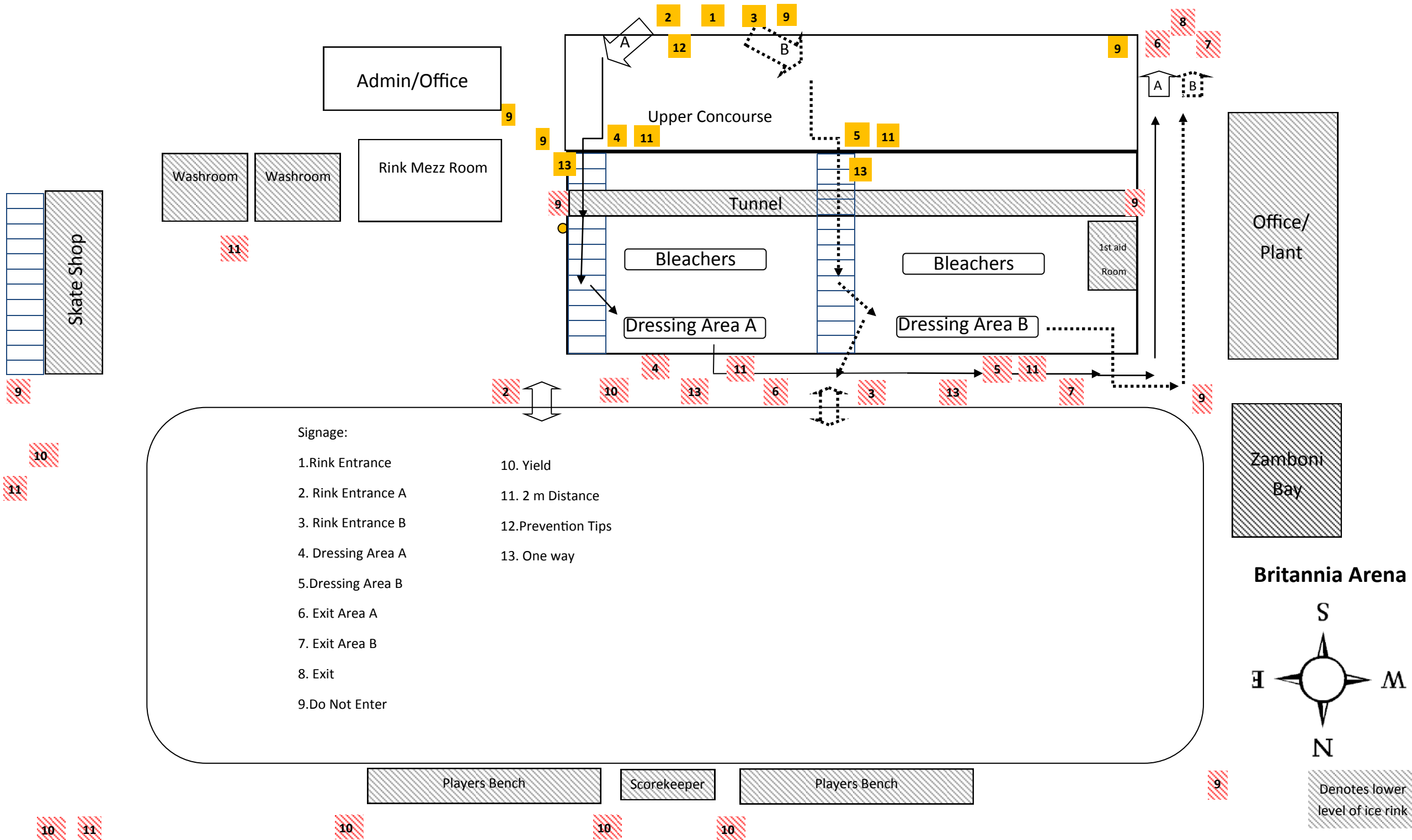

Admin/Office

Upper Concourse

Washroom Washroom Rink Mezz Room

Tunnel

Bleachers

Bleachers

Dressing Area A

Dressing Area B

1st aid Room

Office/Plant

Zamboni Bay

Players Bench

Scorekeeper

Players Bench

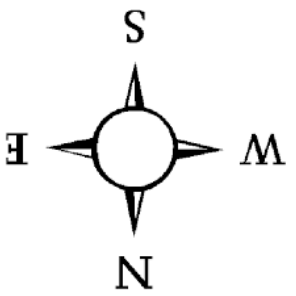

Denotes lower level of ice rink